



# 11-56RKT-GR-ECO

## 5" & 6" LED Gimbal Recessed Light Fixture

### APPLICATIONS

Designed to fit most standard market recessed cans, 5" & 6" Gimbal Light Fixture features an integrated LED power supply and thermal management system combined in a compact unit.

### FEATURES

- Long-life LEDs with up to 50,000 hours at 70% lumen maintenance.
- High quality LEDs utilize 1.18 watts of power.
- Adjustable torsion springs for easy, tool-less installation.
- Durable thermoplastic construction.
- Built-in, high-efficiency LED Driver.
- Dimmable to 10% with most dimmers (see table below).
- Saves 75% over incandescent lamps.
- Standard Edison E26 medium screw-base.
- ETL Listed for damp locations (-20°C - 40°C; -4°F - 104°F).
- Energy Star qualified.
- **5 year warranty** on all electronics and housing.

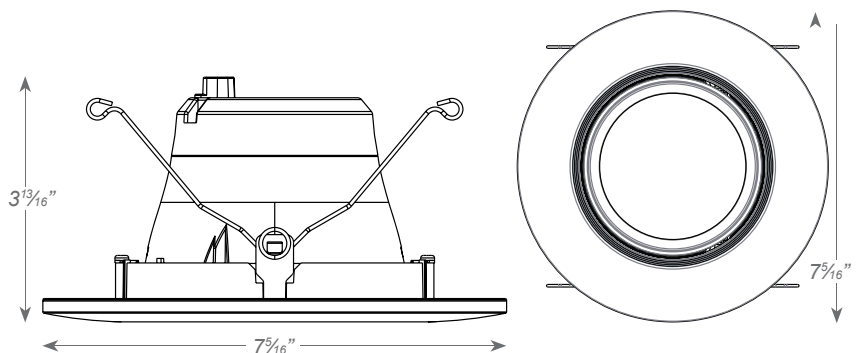

| MODEL               | WATTS |          | COLOR TEMPERATURE |       | LUMENS | OPTIONS |        |
|---------------------|-------|----------|-------------------|-------|--------|---------|--------|
| 11-56RKT-GR-27K-ECO | -14W  | 14 WATTS | -27K              | 2700k | 975    | -GR     | Gimbal |
| 11-56RKT-GR-4K-ECO  | -14W  | 14 WATTS | -4K               | 4000k | 1050   | -GR     | Gimbal |

| COMPATIBLE DIMMERS | MODEL NUMBERS |
|--------------------|---------------|
| Lutron Maestro C-L | MACL-153MR    |
| Lutron Skylark C-L | SCL-153P      |
| Leviton Sureslide  | 6674          |
| Lutron             | PD-6WCL       |
| Legrand Harmony    | HCL453PTCCCV6 |

| PROJECT | TYPE | CATALOG # |
|---------|------|-----------|
|         |      |           |